

axe
EVTOL

SKYFLY



No borders, no barriers, no limits – just infinite opportunities.
Introducing the Axe 2-seat personal vertical take-off and landing EV.

Executive Summary: The Axe - a prototype-proven 2-seat electric vertical lift aircraft

Unique Design

- Take-off and land vertically or like a conventional aircraft
- Hover with ease - advanced flight controller for automatic stabilisation and auto-land
- Four wings give low energy use in the cruise (30-55kw), boosting range and improving safety
- No rotating wings or motors – safer, lighter, simpler, stronger

Safety

- 4 x redundant flight control system
- 8 x motors for redundancy in the hover
- Wings enable 9:1 glide ratio with mechanical controls to all control surfaces for redundancy
- Ballistic parachute

Cost effective

- Affordable at £150,000+VAT
- 80% lower running and maintenance costs compared to comparable aircraft thanks to electric propulsion system and unique design
- Ideal training aircraft to meet demand for commercial eVTOL air taxi pilots needed soon
- Efficient design outperforms most other eVTOL aircraft especially ‘rotors only’ eVTOLs.

Quick to market (2025) with Innovative certification and build approach

- Fixed wing design enables certifying and licensing the aircraft privately as a kit-built aircraft (UK LAA BCAR section S / USA Light Sport Aircraft).
- No lengthy commercial certification - aircraft designed and certified around private owners
- Experienced engineering and design team that have designed, built and certified thousands of aircraft
- Not re-inventing the wheel - we are using established market leaders to supply certified products and systems
- Gearing up for production 2025

Future

- Larger 6-seat private eVTOL (underway)

Table of contents

Executive summary	Page 2
Overview of the Axe Aircraft	
What is the Axe?	Page 5
Why is the Axe different?	Page 6
How does the Axe take-off vertically?	Page 7
Main features	Page 8
Performance figures	Page 10
Technical Overview	
Summary	Page 12
Range	Page 14
Prototyping	Page 15
Computational analysis	Page 16
Specification comparison	Page 17
Pricing	
Pricing overview	Page 19
Options	Page 20
Suppliers	Page 21
Payment Structure	Page 22
Management	
Timeline	Page 23
Facilities	Page 24
Team overview	Page 25
Team CVs	Page 26
Regulation	
Regulatory environment UK	Page 33
Regulatory environment USA	Page 34
Permit aircraft for flight training	Page 35
Light Aircraft Association collaboration	Page 36
Appendices	
Noise Profile	Page 38
FAQs	Page 39
Dimensions	Page 40
Technical component specifications	Page 42
LAA Letter of support	Page 46
Existing Aircraft Market	Page 47
Target Market: Private pilots	Page 48
Target Market: Training organisations	Page 50

You have arrived. Faster, greener, safer, smarter.

*Fly in style with beautiful views, rise above it all
in your **Axe** 2-seat personal vertical take-off and landing EV.*



What is the Axe by Skyfly?

The Axe is a 2-seat, electric/hybrid vertical takeoff and landing aircraft. Use it like a car but live without traffic jams, reduce travel time and enjoy the beautiful views from above. Arrive in style. Whether you commute to work outside city centres, fly to your country home for the weekend, or want an aircraft for your super-yacht, the Axe is an affordable, quiet, sustainable, energy efficient and most importantly, a safe eVTOL aircraft. The whole design has been focused on the private user and tailored to their requirements.



Why is the Axe different to other eVTOL aircraft?

The Axe uniquely does not have rotating engines or rotating wings. The angle of the propellers is set forward at an angle. This design saves weight and doesn't require a complex rotating system that is prone to failure and requires maintenance, all of which keeps operating costs low. With its four wings, the Axe has advantages in efficiency, safety, certification and licencing compared to other eVTOLs, making the Axe the most sustainable and practical personal mobility solution.



How does the Axe take off vertically?

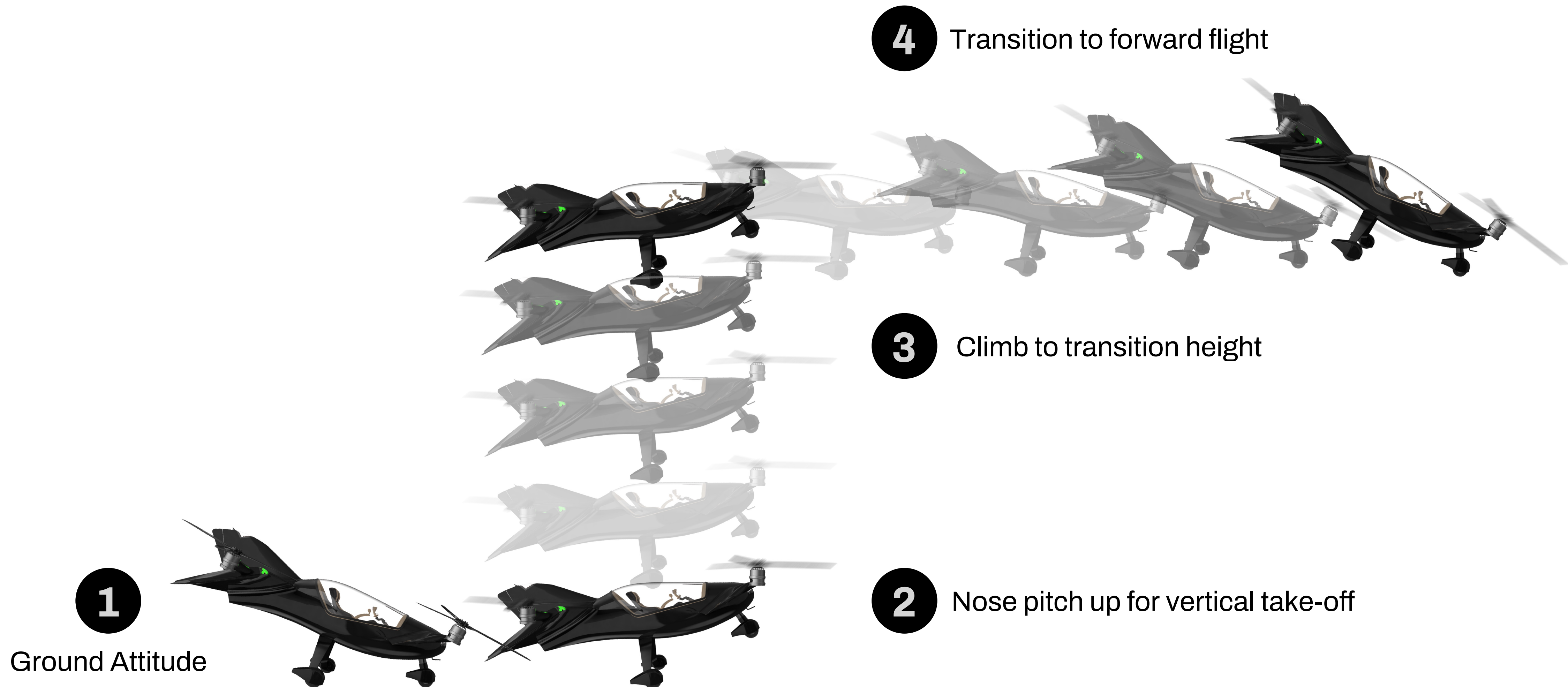

Note:

If space allows, towering take-off not required.

A short take-off and landing (STOL), requiring just 50 metres, is also possible, conserving power and extending range.

Main Features

4 x redundant flight control system

Conventional mechanical control surfaces

9:1 glide ratio

Unique anti-stall (four wing) canard design

Safe and reliable fixed angle motors

8 x redundant brushless electric motors

16 independent Lithium-ion battery packs for redundancy

Removable wings for ease of storage and transport



Wings provide lift during forward flight, increasing battery endurance, speed and ability to glide in emergencies

Manual mechanical controls on aerodynamic surfaces



2 x 35 KW dual redundant electric brushless outrider motors

2 motors powering a single shaft in a single housing per wing-end for single-failure tolerant architecture

100 miles (fully electric)
300 miles+ (hybrid)
Range

2 pax
Passengers

100 mph
Cruise speed



No borders, no barriers, no limits – just infinite opportunities.



172kg
Payload

800kg
Max thrust

8 x 35KW
Electric Motors

Technical specifications

Length	4.3m
Height	3.3m
Wingspan	5m
Overall Span (rotor tip to rotor tip)	8.2m
Maximum all up weight	652kg
Empty weight	234kg (equipped for flight less batteries and occupants)
Payload	172kg (2 pax)
Installed power	4 x 70kw motors = 280kw peak
Batteries	246kg = 49.6kwh
Hybrid	191kg batteries/fuel 55kg hybrid power plant
Rotor diameter	4 x 1.9m (3 bladed fixed pitch)
Rotor Angle	Fixed
Hover Power Required	140kw
Undercarriage	Tricycle (conventional fixed wing)
Stall Speed	55mph
Best Glide Angle	9:1 at 70mph
Climb	2300fpm at 70mph
Runway Length Required	0m - VTOL (vertical take-off and landing) 50m - STOL (short take-off and landing, reducing energy consumption by 50% compared to VTOL operations) 300m - Glide and power off landing



Technical Summary

Propulsion

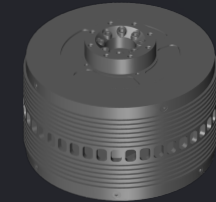

8 individual battery-powered electric brushless outrider motors from Geiger Engineering.

4 rotors, each powered by two motors in a single housing. The duplex motor produces 70kw peak power or 50kw continuous power, and weighs 16kg.

Each wing-end will have a maximum peak thrust of 200kg for the 2 engines, together making a total maximum thrust of 800kg.

For lift off and hover the maximum thrust available will be around 800kg).

Redundancy



Quadruple Redundant flight control system from Embention.

Two motors per wing-end, with one motor able to take on 60 percent of the overall performance without delay.

16 independent batteries enable the aircraft to continue flying should one or more battery system fail.

In the unlikely event that of an electrical failure, the aircraft is still controllable in the glide for an emergency landing using the mechanical control surfaces (ailerons, elevators and rudder) of the aircraft.

Ballistic parachute can return the aircraft and occupants safely to the ground if a glide landing is not possible.

Extended Range



The 4-twin-engine rotors are mounted on the ends of each of the 4 wings at a fixed angle.

The wing spar acts as an motor mount, the main wing support and contains the motor mounting arm. Above 60 knots, lift comes from the wings and the motors are used only to propel the aircraft forwards

The design of the wing is critical because it is a major load bearing structure as well as a means of providing lift to save battery power, increased air speed.

The optional hybrid generator unit is used to charge the batteries in flight and boost the range up to 300 miles

What is the range of the Axe?

We have created a mathematical model, proven by CFD, real-life data from our prototype testing and motor testing which enables us to predict performance.

This graph shows the relationship between speed and power (KW), range (miles) and endurance (minutes).

Most notably from this graph, you can see there is a significant drop in power as speed increases thanks to our efficient wings providing lift above the stall speed. The Axe uses approx. 130KW of power in the hover (at max payload) and then around 30-50KW of power once wing borne. As you can see from above conventional take-off and landing saves up to 2/3 of your energy usage compared to vertical take-off.

The forecast maximum range as a fully electric aircraft is approximately 100 miles (1hr at 100mph) – **with the hybrid generator, it is expected to achieve over 300 miles.**

The lowest cruise speed without losing efficiency is approximately 55mph – this also gives you maximum endurance also of 1hr 21min for a fully electric solution at maximum payload.

The Axe eVTOL uses existing battery technology, contrary to competitors who are waiting for battery capacity breakthroughs

Speed	Payload	Endurance
55 mph	172kg (2 pax)	1 hr 21 min
55 mph	86kg (1 pax)	1hr 42 min
90 mph	172kg (2pax)	1hr 3 min
90 mph	86kg (1 pax)	1hr 10 min

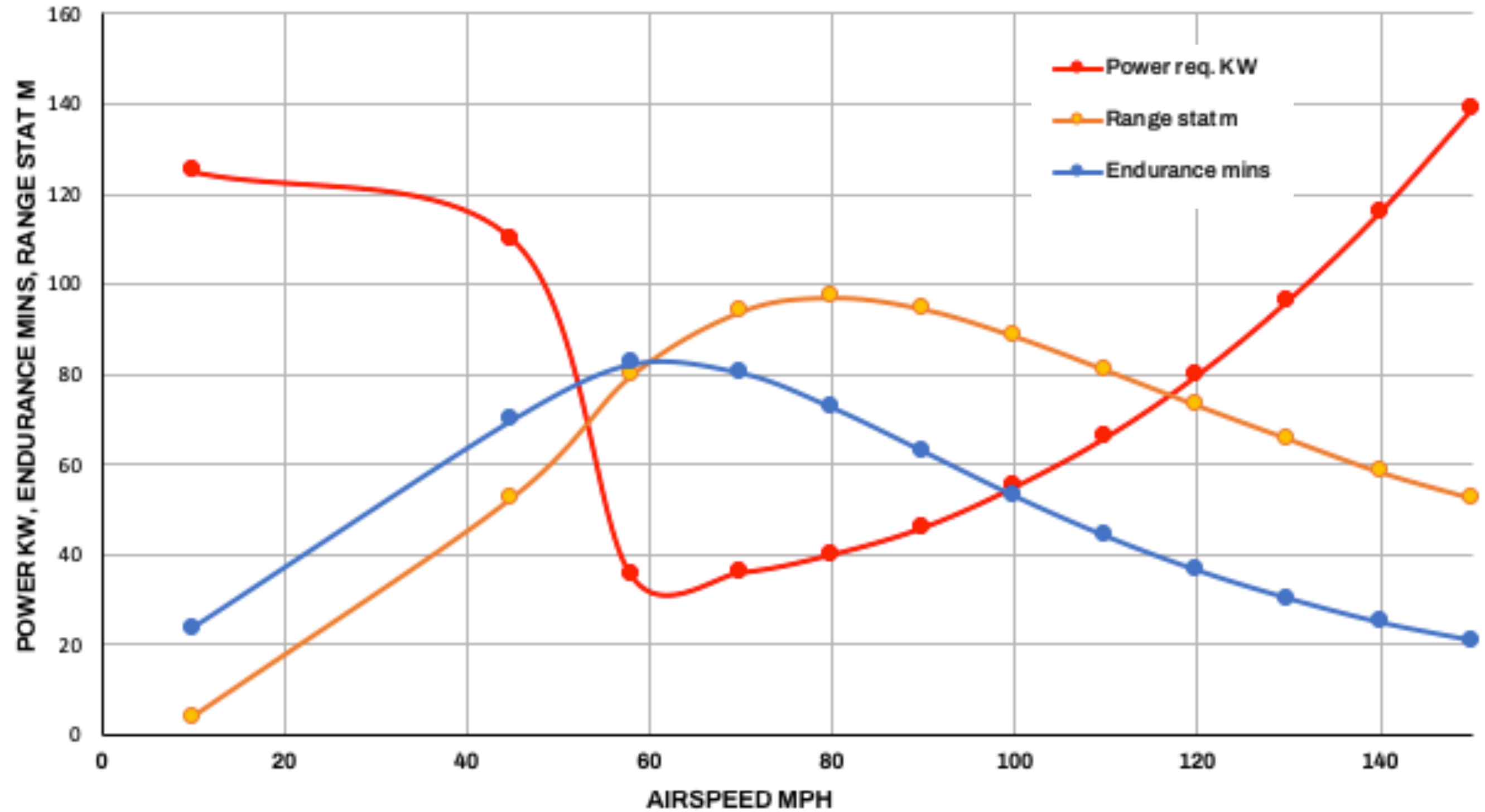

Proof of concept - Axe Prototype

We have successfully built and run a test programme on the prototype Axe eVTOL.

The prototype was built using custom tooling and composite construction methods that replicate our full-scale prototype. Through doing this, we have been able to fine tune the build process to maximise the quality of the finish and speed of construction.

Being able to test the aircraft as a prototype proves our CFD and design work and enables us to test the projected performance of the aircraft.

The prototype has also enabled us to tune our flight control system to optimise the hover stability and transition smoothness.

Video available to view on our [Youtube channel](#).



Design and Computational Fluid Dynamics (CFD)

The aircraft has gone through several iterations of aerodynamic development and design work. The initial work focused on wing section selection and establishing the optimal angle of attack. The objective was to investigate the net drag and lift from different configurations so as to select the most appropriate configuration that would meet the performance requirements of the final aircraft.

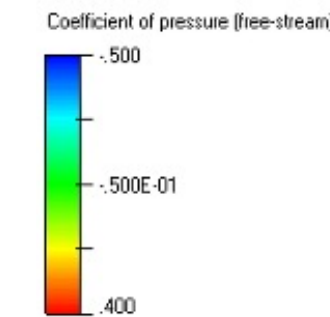
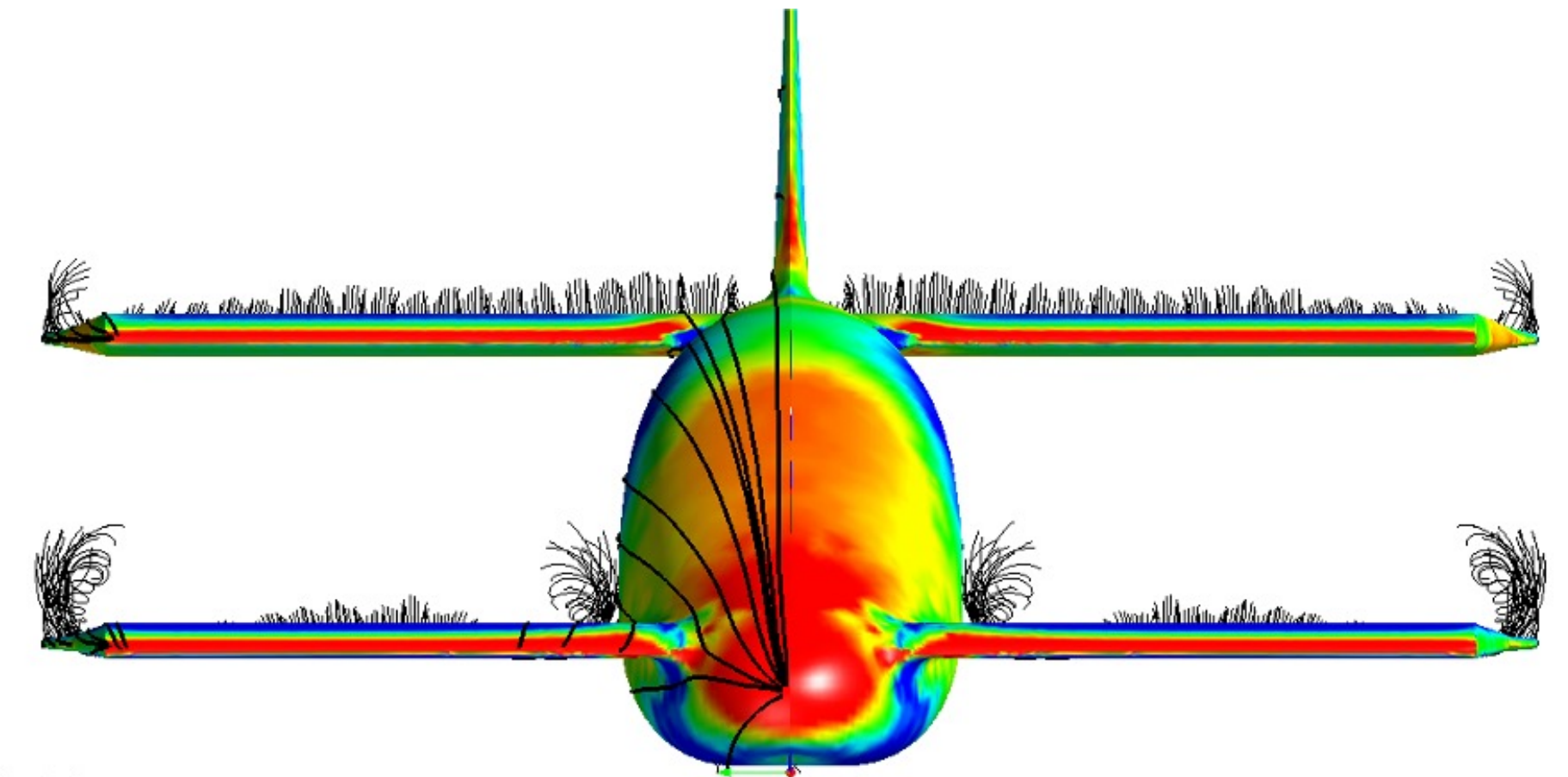
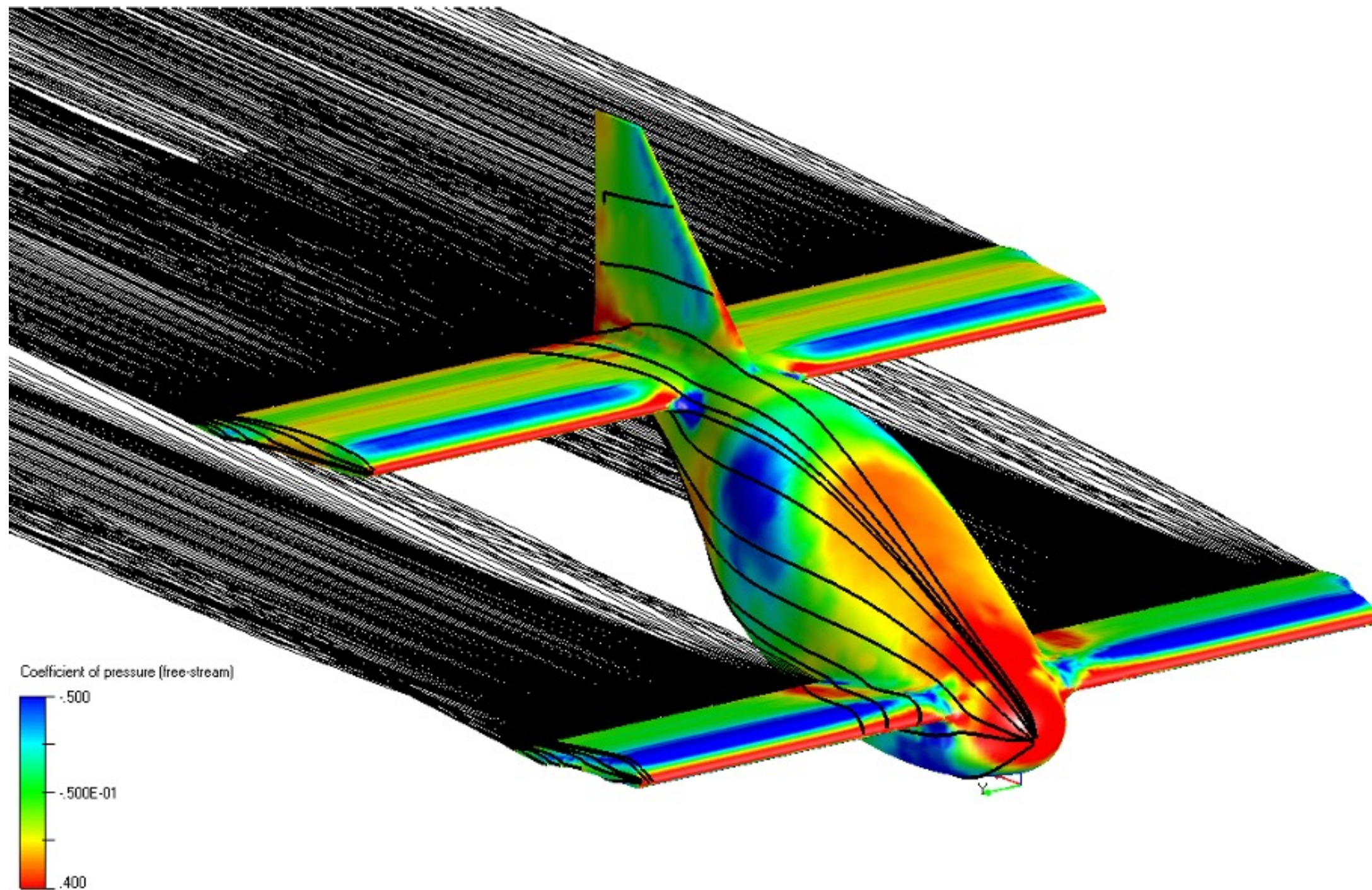

The methodology adopted involved the use of state-of-art, computer aided design (CAD) and computational fluid dynamic (CFD) tools. These commercially available software products are customised to enable a matrix of possible flight conditions to be analysed. The knowledge gained on the configuration enabled data release for tooling of a 1/3 scale development prototype (unmanned). The images featured on this page show extracts of the above process. The colour contours indicate surface pressures which are converted into lift and drag. Several findings from our CFD work have led to us identifying patentable performance enhancing features within our design which further set us apart from our competitors.

2 seat personal eVTOL comparison



Personal eVTOL	Axe by Skyfly	Air one	E-Hang 216S	Doroni H1
Website	www.skyfly.aero	www.airev.aero	www.ehang.com	www.doroni.io
Range	100 miles (electric only) 300+ miles (hybrid)	100 miles	22 miles	60 miles
Cruise Speed	100 mph	100 mph	62 mph	100 mph
Price	\$180,000	\$150,000	\$410,000	\$195,000
Glide Ability	✓	✗	✗	✗
Complete Power Redundancy*	✓	✗	✗	✗
PPL Ab-initio Training Capable*	✓	✗	✗	✗

*Complete Electrical Redundancy – The ability for an aircraft to fly in a glide and land, in the event of a complete power/electronics failure.

*Ab-initio Training Capable – No "eVTOL" pilots license exists yet, a private pilot's license requires the aircraft to fly, land and take off like a conventional aircraft.

1 seat personal eVTOL comparison



Personal eVTOL	Jetson	Helix Pivotal	Lift Hexa
Website	www.jetsonaero.com	www.pivotal.aero	www.liftaircraft.com
Endurance (range in mins)	20 min	20 miles	15 min
Cruise Speed	63 mph	60 mph	45 mph
Price	\$98,000	\$195,000	\$495,000
Glide Ability	✗	✗	✗
Complete Electrical Redundancy*	✗	✗	✗

*Complete Electrical Redundancy – The ability for an aircraft to fly in a glide and land in the event of a complete power/electronics failure.

Base price £150,000

Factory assisted build £20,000

Range extender generator £50,000

Ballistic parachute £20,000

Additional battery pack £25,000

Prices exclude VAT and are subject to change to fall in line with inflation and change of suppliers.



You have arrived. Faster, greener, safer, smarter.

SKYFLY

axe

Aircraft Options

Ballistic parachute

We have teamed up with Galaxy GRS, the biggest European producer of parachute ballistic rescue systems aimed at ultralight aircraft. The GRS systems use parachutes, that are able to open quickly even at low speeds as well as high speed enabled by a well-thought-out design. The system will weigh a total of 12.3kg installed and is rated up to 600kg with a maximum load of 750kg at 250km/h. The parachute provides our customers with another failsafe which can be used in the event of an emergency.

Factory build assist course

Owner-operators can choose to attend the Skyfly production facility on a one-week factory workshop where you assemble your own aircraft alongside our approved engineering and assembly team. This will give owners an unparalleled insight into the aircraft's inner workings, manufacturing process, and rationale behind aircraft operating procedures and limitations. It allows the user to gain considerable advantage and safety awareness and an unforgettable experience to launch your Axe aircraft ownership.

Quick release wings

Bolstering our offering for private pilots and flight schools, the aircraft will have removable wings as standard that are aimed at giving as much flexibility for our clients to transport the aircraft in a trailer, and remove them for ease of storage. It also enables flight schools ultimate flexibility in where they can provide students with flight training. Further to this, the design supports our goal towards ease of ownership for our client and encouraging clients to avoid hangarage fees and store at home in their own hangar or garage.

Additional battery pack

In addition to the solid state battery system in the aircraft, an additional option for our customers is for a removable battery pack which can be used in place of the passenger seat to extend your range by at least 50%. If the owner had 2 additional packs, it would also enable you to have a battery system charging on the ground whilst you are up in the air. Depending on your charging speed, this will enable you to continue flying without waiting for your aircraft to charge.

Hybrid Generator System

Working with Rotron and Turbotech we are adding the option for a hybrid generator system to extend the range of the aircraft up to 300 miles. The Rotron rotary engine delivers an efficient and reliable solution for use with heavy fuels. This compact, twin rotor engine utilises advanced fuel management techniques to achieve reliability in operation, high power-to-weight ratio, low fuel consumption and reliable starting under the most extreme of operating conditions. Turbotech is the first company in the world to introduce regenerative turbines for aeronautical applications. Turbine engines have a notably higher reliability (MTBF) and lifetime (TBO) than its piston counterparts and highest power to weight ratio, compared to any other electricity storage technology.

Suppliers

We have identified suppliers that have a proven history in aviation. By using 3rd party hardware and software, we ensure we have safe, proven and reliable components that will enable us to hit our build schedule on time.



Flight Control Systems

Embention have 15 years' experience in the autonomous vehicle industry, developing high-performance systems for UAVs and eVTOL vehicles in compliance with aircraft certification standards. Embention will supply the Axe with their quadruple redundant flight control system.



Propulsion

Geiger Engineering specialises in the design and manufacture of electric aircraft engines and related systems, including batteries, electric controllers and aircraft propellers. Geiger's electric motors have a proven track record over the past 5 years flying in real electric aircraft applications.



Hybrid generator (piston) system

Rotron Power Ltd is a specialist manufacturer of advanced rotary engines. Rotron have been at the forefront of rotary engine design. The Rotron system will provide us with an unrivalled power-to-weight ratio hybrid generator system which will enable us to significantly increase the range of our aircraft.



Hybrid generator (turbine) system

Turbotech is the first company in the world to introduce regenerative turbines for aeronautical applications. Turbine engines have a notably higher reliability (MTBF) and lifetime (TBO) than its piston counterparts and highest power to weight ratio, compared to any other electricity storage technology.

Payment Structure

Stage one – Deposit

1. Reserve your build slot £1000+VAT
2. 10% Deposit payment to secure the slot (£15,000+VAT)

Once the customer has signed the purchase order agreements and settled the reservation fee- the deposit is called upon. Following which, we formally issue your serial number.

Stage two – Manufacturing

65% Manufacturing payment £100,000+VAT (plus options)

The manufacturing payment enables us to begin building your aircraft. This will be called upon 6 months before your build slot. At this point we request further requirements on customisation and options.

Stage three – Final payment

20% Final Payment £35,000+VAT

Final fee prior to the delivery of your aircraft

Stage four – Delivery

Delivery estimated 2025

Timeline

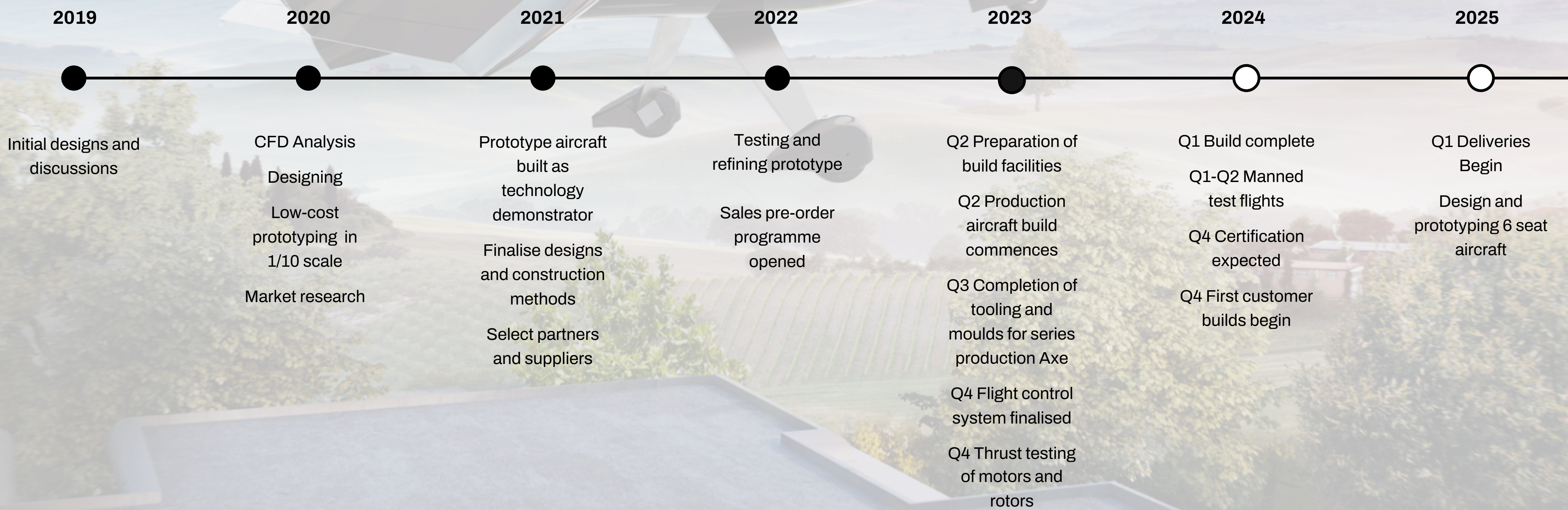

Skyfly HQ / UK Assembly facility (UK)

- Richard Tuthill, owner of road, rally and race car manufacturer [Tuthill Porsche](#), has invested in Skyfly and joins as head of assembly and manufacturing.
- The partnership looks to strengthen Skyfly's affinity with high-end automotive production methods and light-weight engineering practices.
- The Skyfly HQ and Assembly facility is based on the same site of Tuthill Porsche with a whole host of state-of-the-art facilities and machinery.
- Further facilities are to be established in the USA with our partners



The Porsche 911K by Tuthill Porsche (850kg 11,000rpm)

Team Overview

Board and Senior Management				
Michael Thompson Co-founder and Chief Executive Officer	Jaap Rademaker Co-founder and Chief Commercial Officer/CFO	Dr William Brooks Chief Technical Officer		
Engineering Team				
John Wighton Structures and certification	David Barden Lead Design Engineer	Richard Tuthill Assembly and Manufacturing	Rob Martin Composite structures	Seb Smith Electrical Engineering
Dmitrijs Gnennijs Composite structures	Devan Rudolph Aerospace Engineer	Phil Hall Engineering and Certification	Milford Killian-Dawson Mechanical Engineer	Dylan Burkey Aeronautical Engineer
Flight Operations				
Sqn Ldr (Ret'd) Chris Heames Flight safety	Kai Maurer Pilot Training and Licensing	Flt Lt (Ret'd) Michael Laws Flight Operations		
Engagement and Distribution			Legal	
Edwin Brenninkmeyer Europe	Bill Minkoff United States	Julian Massey	Harper James	
Media and Communications				
Marcus Monsell Marketing	Adam Landau Head of Communications	Alex Prins Media Coordination	Tom Ansell Customer experience	
Board Advisors				
Bachir Rabbat Board advisor	Donough Tierney Board Advisor and Industry Expert	Mark Johnson Board Advisor and Industry Expert	Arnaud Flecchia Board advisor and Finance	

Board and Senior Management

Michael Thompson
CEO



Entrepreneur with a background in unmanned aircraft technologies running one of the UK's leading drone companies offering professional UAV solutions in surveying, inspection, film sectors for a wide range of large multinational agencies and blue-chip organisations. Having set-up and run the business from the start, Michael has experience running a business and building a team around him that is efficient and effective. Michael's role over the past 6 years has been running all areas of the flight operations at his company and developing safety cases for CAA operational authorisations. He has over 600 hours of commercial UAV pilot experience. He is a qualified helicopter pilot rated on the Robinson R22, R44 and soon Airbus H130 helicopters.

Jaap Rademaker
CCO/CFO



Jaap is a lawyer and economist who worked with a large international law firm until 1999 to then become an investment banker with JPMorgan and Deutsche Bank in London structuring and trading fixed income and equity derivatives for over a decade. Since 2011 Jaap runs a boutique financing firm, sourcing, structuring and arranging alternative asset transactions and investing for clients and as a principal, with a specific passion for new greentech. Jaap enjoys making solutions happen in challenging and complex situations whilst implementing commercial and financial strategies; he has a track record of consistently successful transactions. Commutes around Europe in his small, eco friendly private aircraft.

Dr William Brooks
CTO



Experience in design, certification and manufacture of light aircraft – was CTO at P&M Aviation Ltd responsible for design, certification, manufacture and testing of aircraft, specialising in flex-wings and composite structures. Designed and certified 19 types of aircraft to date and oversaw manufacture of over 2,000 aircraft of his designs now in service. Aeronautical engineering and certification consultancy - clients include Rolls Royce, Westlake, Pegasus Sport Aviation Ltd and GS Aviation Ltd. Degrees in Industrial Design, Aircraft Design, Cranfield University – MSc. PhD – Field of Study: Aircraft Design, Composite Structures. 3,700 hours in a mixture of aircraft, hang gliders, experimental aircraft. He has been chairman of the Royal Aeronautical Society Human Powered Flight group for 20 years.

Engineering team

John Wighton

Structures and certification



John has over 35 years of experience in the aerospace industry. His first consultancy business was started in 1988, encompassing over 250 projects to date. He has also been appointed in several senior roles, including Chief of Stress at Pilatus Aircraft, Switzerland and Head of Certification at Assystem and Lead Technology Manager at Fokker Aerostructures. He holds a number of delegated technical signatures, for stress (level 2) and FEM with Airbus (A380 and A350) and previously headed up both CAA E1/E2 and EASA 21J design organisations. He is a Fellow of the Royal Aeronautical Society. John most recently has been involved with aircraft design and perform engineering analysis (stress) for Rolls Royce and the ACCEL programme.

David Barden

Lead design engineer



David graduated with a masters from of Swansea University in Aeronautical engineering. Following his studies, David worked as part of the production team manufacturing the composite light aircraft called the e-GO aircraft. This involved ground up research and development into composite parts and manufacturing techniques as well as design of components. Following on from this, David started at Barnard Microsystems Ltd building and operating VTOL UAV's for both industrial and defence applications. His work included designing and manufacturing composite parts from CAD and the operation, setup and testing of the fixed wing, multirotor and hybrid production and experimental UAVs.

Richard Tuthill

Assembly and Manufacturing



Richard Tuthill, owner of road, rally and race car manufacturer Tuthill Porsche. With over 40 years' experience building and restoring bespoke Porsche for customers around the world, Tuthill Porsche is synonymous with the world's most successful Porsche rally and race cars. They are perhaps best-known for their Safari 911s and, more recently, their Porsche 911K, a spin off of the iconic 911 which Tuthill Porsche re-engineered to achieve a wet weight of just 850kg. Richard will strengthen Skyfly's affinity with high-end automotive production methods and light-weight engineering practices. Richard Tuthill is a private pilot with a keen interest in personal air transport.

Seb Smith

Head of Electrical Engineering



Seb comes from an automotive background, bringing a wealth of experience having worked at McLaren, Jaguar Land Rover and Rivian. Prior to joining Skyfly, Seb conducted the ground up development of an off the shelf classic car retrofit kit for the Porsche 964 including the vehicle Control Unit (VCU) and the CCS Rapid charging system for Zero EV. Seb has a Masters degree in Computing and Electronics and has extensive experience of designing safety critical control systems, specialising in electric powertrains. They're hands on and practical approach to designing and problem solving has enabled the development of the Axe's propulsion system to progress expeditiously.

Rob Martin

Composite Structures



Composite engineer and recognised inventor, Rob Martin has over three decades of experience in manufacture. During this time, he has worked on various projects including C.U.E.R, Thales Watchkeeper UAV and award-winning teams of the Rolls Royce ACCEL G-NXTE electric speed record aircraft, and e-Go aeroplanes. In 2022, he formed the LAA composite school, inspired by his work as a guest educator at Cambridge University.

Engineering team

Dmitrijs Gnennijs
Electrical systems engineer



Dmitrijs studied computer science at the University of Warwick following which he worked for Warwick Racing as electronic systems engineer involved with all aspects of the powertrain developing everything from HV battery systems to ECUs. Following this, Dmitrijs moved to Vass Technologies Ltd where he was an embedded software developer developing from scratch software for all embedded devices on electric car conversions.

Devan Rudolph
Aerospace Engineer



Devan is an Aerospace Design and Mathematical Modelling Engineer with a multidisciplinary background in Electrically Powered UAV design, aircraft design and testing, flight dynamics and control, mathematical modelling of dynamic systems, engineering design and simulations, mathematical modelling of biomechanics of human motion and applied mathematics.

Phil Hall
Engineering and Certification



Phil has been involved with aviation engineering since joining the RAF in 1968 and has built various light aircraft and engines himself since leaving the service. As an approved LAA inspector with two decades of experience, Phil carries out formal inspections and guidance for repairs of home built and vintage aircraft, and is a approved CAA/LAA flight test pilot.

Milford Killian-Dawson
Mechanical Engineer



Milford holds a Master's degree in Mechanical Engineering from Imperial College London, specializing in areas including mechatronics, stress analysis and fracture analysis. He is also a professional drone pilot and extensive knowledge in drone building and tuning of novel unmanned aircraft systems.

Dylan Burkey
Aeronautical Engineer



Dylan studied Aeronautics and Astronautics at the University of Southampton and is now an aeronautical engineer with expertise in design, optimisation and manufacturing. He has particular experience in CAD design and CFD analysis.

Engagement and Distribution

Bill Minkoff
USA



Bill Minkoff was a US navy pilot, with 300 aircraft carrier landings and was a Navy Strike Fighter Weapons School graduate and instructor; holds a BA from Rutgers in Economics and an MBA from Vanderbilt; holds an Airline Transport Pilots Certificate with ratings for light to heavy jets. Bill went on to be a Delta Airlines Line Check Captain and to have careers in Aviation Safety and Accreditation and has businesses in the Private Jet space and a Tecnam aircraft sales and service centre in the United States and regularly speaks at Aviation and Air Mobility symposia, being Vice President of the Advanced Air Mobility Association.

Edwin Brenninkmeyer
Europe



Edwin Brenninkmeyer, founder and CEO of UK based Oriens Aviation and investor in complimentary US aviation businesses, has joined Skyfly as a strategic investor, offering his experience and expertise. Oriens Aviation is a UK-based aircraft dealership, service centre and operator, working with exclusive rights in the British Isles to represent major business and general aviation Original Equipment Manufacturers (OEMs). Edwin's U.S. investments are in disruptive and innovative aerospace markets, uniquely positioned to generate demand for future Advanced Air Mobility (AAM) operators. Edwin will use his marketing infrastructure and networks to advance the unique proposition of the Axe, with a specific focus on the Axe as a cost-effective fixed-wing/E-VTOL trainer aircraft.

Julian Massey
Business Development



Julian holds an MBA and a Commercial Pilot's Licence. He has built up and owns an automotive components business and a commercial property development business.

Media and Communications

Marcus Monsell
Marketing



Marcus comes from a background in film production, initially seeing a market opportunity in the infancy of the drone industry, with his business partner he built up one of the leading aerial filming companies in the UK, The Drone Co. Later he has started Mystify London, providing a whole suite of marketing solutions.

Adam Landau
Head of Communications



Adam has a First-Class degree in journalism and has won multiple national awards for his work. Passionate aviator and regular contributor to a variety leading aviation publications. Adam is a skilled aviation videographer/live broadcast camera operator/commentator specialising in airshows. Adam is also co-host with PlanesTV, including for the official live broadcasts of NATO Days, the world's biggest military airshow (the Royal International Air Tattoo).

Alex Prins
Media Co-ordination



Alex Prins is a graduate from the University of Exeter with experience as a writer and editor for a variety of international publications. Alex is an award winning aviation photographer and drone pilot who will be managing Skyfly's media assets alongside assisting the team in shooting content for our social media pages and for our updates to investors and customers.

Tom Ansell
Customer Experience



Tom's career has been centered around on customer care. Working initially as a 'Genius' in Apple's flagship store in Covent Garden, London, Tom was head hunted by premium sports and luxury car retailer Pescara as the head of after-sales customer care. Before working with Skyfly, Tom worked as account manager for The Drone Company working with multiple international clients in both creative sectors and industrial applications

Flight Operations

Sqn Ldr (RAF) Chris Heames (retd)
Flight Safety



Chris is a former RAF Squadron Leader, a pilot with 12,500 hours experience including 6,000 on a range of military jet fighter aircraft, a senior examiner, combat instructor, highly experienced aerobatic pilot, glider pilot, instructor, and senior air accident investigator.

Kai Maurer
Flight Training



Qualified Gyroplane Instructor and Examiner with over 6,000 hours on Gyroplanes. Kai was instrumental in writing the Gyroplane syllabus and certification in the UK. Elected as an Upper Freeman of The Honourable Company of Air Pilots.

Flt Lt. (RN) Michael Laws (retd)
Flight Operations



Michael flew Sea Harrier GR.1 and GR.2 vertical takeoff and landing aircraft including active carrier duty in the First Gulf War, and in subsequent civilian life focused on infrastructure construction management.

Advisory Board

Bachir Rabbat



Senior Executive offering 30 years' comprehensive achievements across diverse sectors and multiple geographies. Specific expertise within start-up organisations, transformation for growth and diversification strategies..

Donough Tierney



Over 20 years' International Aerospace & Defence experience. Don is an expert in Internationalisation of Aerospace, IT/Electronics and Security. He has worked for companies like Xerox, Mitsubishi, EADS & Airbus.

Mark Johnson



Mark has worked in aerospace for 40 years. Following a number senior positions at Dunlop Aerospace, Mark founded Sigma Components and progressively grew this aerospace company from a 'start-up' to having a turnover of over £50m, employing over 800 people in the UK and China.

Arnaud Flecchia



Entrepreneur in the Security and Mobility industries for the past 20 years, having built businesses of £20m+ turnover with European presence through organic growth and acquisitions. Skilled in Business Strategy, Corporate & International Development.

Regulatory Environment (UK) - Kit Built Aircraft with the CAA/LAA



The main certifying body for aircraft in Europe - the European Union Aviation Safety Agency (EASA) - has released a set of special conditions for eVTOL aircraft which provide companies with an outline route to gain certification. This will enable aircraft to be used and sold both privately and commercially.

This is the route that our competitors are taking to gain certification. However this process is proving time consuming and expensive, with launch dates being pushed back.

Skyfly's approach is to initially bypass this route to market and certify the aircraft under existing light aircraft regulations (via the Light Aircraft Association) saving us a huge amount of time and expense.

Our approach to certification for our first aircraft, is via the British Civil Aviation Authority (CAA). Specifically, our aircraft falls under the airworthiness regulation group of Small Light Aircraft (BCAR - Section S) as a kit-built aircraft.

This is a less regulated category that will enable us to gain a permit to fly and sell our aircraft in a fraction of the time to the General Aviation market (private owners). Most importantly, this category of certification has moved from 450kg maximum take-off mass (MTOM) to 600kg MTOM making it feasible for our aircraft to be certified in this class.

The CAA has identified that General Aviation is the foundation for air transport and aerospace recruitment – hence development in this sector has been largely deregulated and innovation encouraged.

In relation to the kit-build element of our aircraft, "the 51% Rule" is a term commonly used. It requires the owner, rather than the manufacturer, to perform the majority of the fabrication and assembly in order to be issued with a Certificate of Airworthiness.

Our customers will join us at our manufacturing facility and participate in a 1-week construction course to build the aircraft with one of our engineers.

This is the market that we will operate in initially, in order to build a market reputation and develop an aircraft in an inexpensive way, with a view to entering the certified market as the industry matures.

Our aim is to have the advantage of successfully proving the concept in this category and being the first business to build and sell an eVTOL aircraft in the UK.

Regulatory Environment (USA) - Light Sport Aircraft Category



The Federal Aviation Administration is set to recognise the Axe eVTOL as a Light Sports Aircraft, as part of proposals to reform their light aircraft certification requirements. Previously, only single-engine aircraft could be classified as LSAs. However, recognising the part that electric aircraft will play in the future of General Aviation, the reformed rules will allow LSAs to have “any number or type of power plants.

Known as the Modernisation of Special Airworthiness Certification (MOSAIC) Reforms, the new rules recognise the importance of sustainable, efficient electric aircraft and intend to increase the suitability of such aircraft for both private use and pilot training.

Classifying the Axe eVTOL as a Light Sport Aircraft (LSA) means pilots will be able to fly the Axe using a Sport Pilot Certificate (SPC). This creates opportunities for non-pilots to qualify to fly the Axe more easily than ever before, while also enabling thousands of existing SPC pilots to fly the Axe without needing to ‘upgrade’ to a full Private Pilot Licence.

Minimum training requirements for an Sports Pilot Certificate (SPC) are less than half that of a full Private Pilot Licence (PPL), and a PPL can typically be almost three times as expensive to obtain.

The Axe has 8 electric motors and four wings, providing multi-layered safety redundancy, as well as whisper-quiet operation compared to old-fashioned fossil fuel burning helicopters or airplanes. Most eVTOLs will not be covered by the new rules as powered lift aircraft are explicitly excluded from being considered LSAs. However, the Axe qualifies as an LSA thanks to its unique four four wings giving aerodynamic lift and its fixed 45-degree angle rotors which make it capable of operating as a normal airplane.

Permit Aircraft for Flight Training

CAA regulation on permit aircraft being able to carry out flight training changed in 2020 with the release of ORS4 No.1271. This enables new owners to be trained on their own permit aircraft and existing license holders to be able to carry out training and differences training on permit aircraft.

Extract from CAA:

“After substantial consultation with internal and external stakeholders, we now allow flight instruction and self-fly hire to utilise aircraft flying in accordance with a National Permit to Fly subject to specified conditions. This relaxation has been published through an additional General Permission and is designed to sit alongside the General Permission already in place for Type Approved microlights and gyroplanes.

This permission does not apply to flight instruction and examination where the recipient does not hold a licence, except when the recipient is:

- The registered owner or joint-owner, or
- A registered shareholder of the company of which owns the aircraft, or
- Is the spouse or child of a registered sole or joint owner.”

Light Aircraft Association collaboration

Skyfly is working with the Light Aircraft Association on various aspects of the certification and pilot licensing of the Axe aircraft. The LAA are the UK's principal representative body for amateur-built and light aircraft.

By working with the LAA, we gain access and are able to collaborate with the LAA design and engineering teams.

Their organisation is delegated by the CAA to cover a number of vital areas that are fundamental to the Axe development programme and eventual role out. Areas we will be using the LAA:

- Testing under E-conditions
- Certification under BCAR sections S with LAA recommendation to the CAA on what additions to existing framework needs to be added to satisfy CAA for our aircraft and indeed further eVTOL aircraft.
- Establishing a basis for pilot licensing under NPPL regulations with differences training

Skyfly has received a letter of support from the LAA to show our stakeholders that we have the backing, knowledge and contacts of the LAA to support us on our path to certification. (Letter appended)

Appendices



You wish the journey was longer. Faster, greener, safer, smarter.

Rise above it all in your Axé 2-seat personal vertical take-off and landing EV.

Noise Profile

Recordings made by NASA engineers have demonstrated an acoustic profile for an electric vertical take-off and landing aircraft **below 65 dBA which** represents a noise level comparable to a normal conversation at a distance of 330 feet from the flight path.

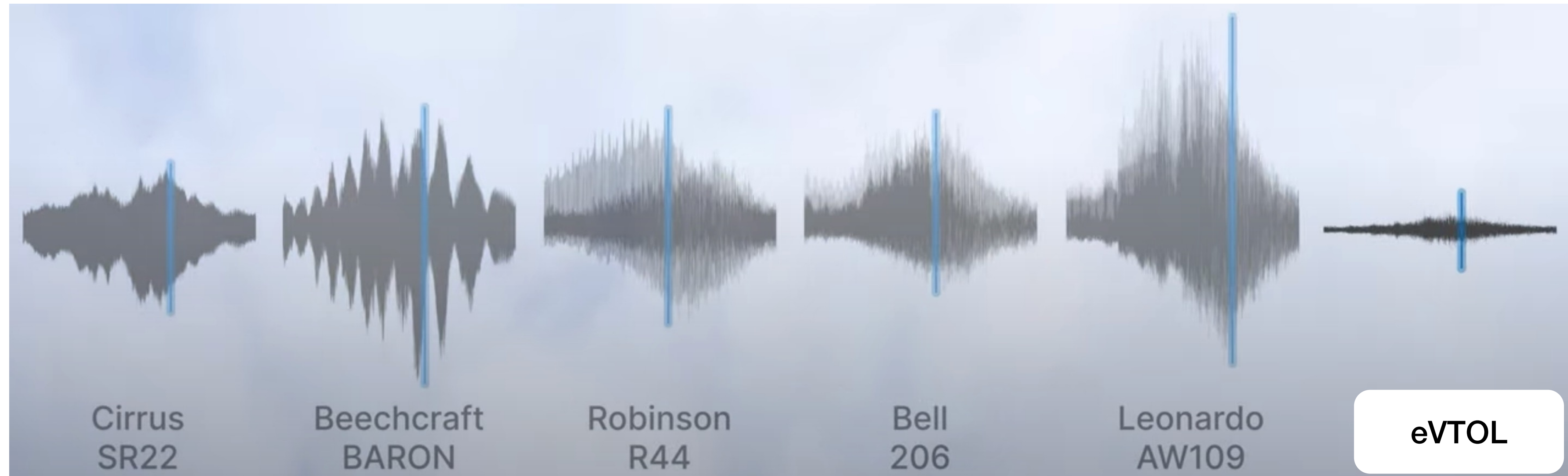

FAQ's - for more visit www.skyflytech.com/faq

Can I fly my Axe?

The Axe's unique design means it can operate like a conventional fixed-wing aircraft, despite being able to land and take off vertically – but don't worry, vertical take off and landing is not like a complex and difficult to fly helicopter – the Axe's advanced flight control system means it can be flown easily, just like a consumer drone.

Although EVTOL pilot licenses don't exist yet, you can forget about waiting for regulators to catch up: the Axe can be flown with a normal private pilot's license. Flying should be a breeze. With the Axe, it can be.

Why is the aircraft safe?

The Axe is powered by 8 electric motors, which enable you to continue hovering even if one or two motors fail. The aircraft features a quadruple-redundant control system from Embention, one of the leading manufacturers of manned electric aircraft flight control hardware. This gives you multiple layers of redundancy in your flight control system. We are using proven systems with existing aerospace grade certification. The battery system is redundant, if one system fails, the other seamlessly takes over.

In the unlikely event all motors or systems fail, the high-lift wings and mechanical linkages to the control surfaces enable the aircraft to glide to safety and land normally. The wings are set up in a unique "canard" configuration such that you cannot stall the aircraft. Finally, in the event that you have no other safe options to glide to safety, the aircraft is equipped with a ballistic parachute system. The system is activated by a lever in the cockpit which launches a rocket carrying the parachute out from the aircraft. This has been designed to carry the whole weight of the aircraft, 2 passengers, and luggage to safety.

Why is the Axe different to other eVTOL aircraft?

Wings: Whilst the Axe can take-off vertically, with our 4-winged design, the Axe in forward flight flies like a normal aeroplane – including mechanical control linkages to your control surfaces which enable you to glide and land even with a complete system failure. The wings drastically improve range (140kw of power in the hover vs 30-50kw in forward flight).

Weight: The Axe has focussed its engineering efforts to minimise weight across the whole aircraft. This has led to an all up weight of just 650kg. This has been achieved through the use of Carbon Composite structures over the whole airframe.

No Rotating mechanisms: Most eVTOL aircraft rely on failure-prone, complex, and maintenance-intensive rotating/tilting mechanisms for motor and rotor. But not us. The Axe does not have rotating engines or wings, saving you weight, operating costs, and purchase price compared to other eVTOLs.



Dimensions (mm)

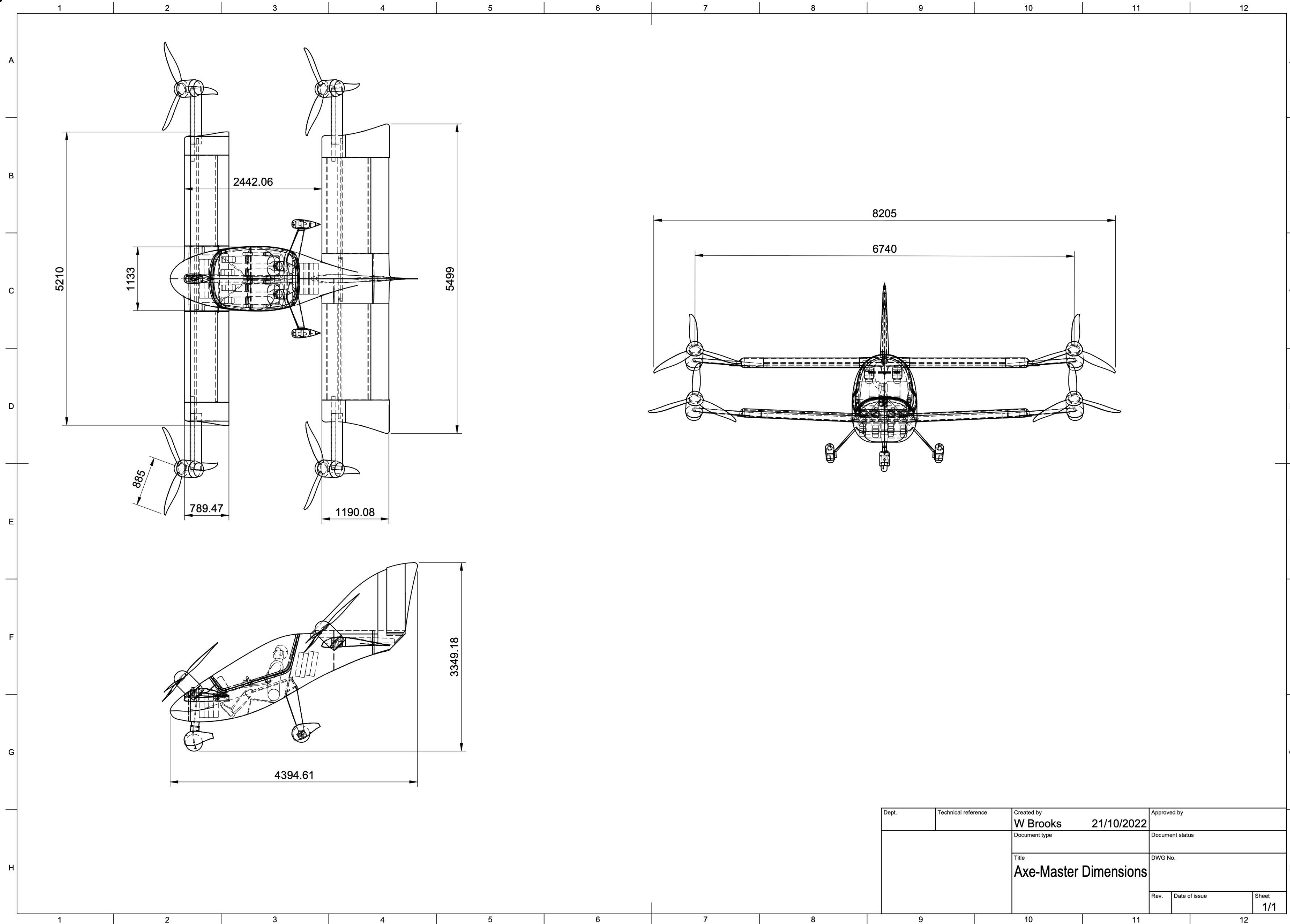

Trailer Dimensions (mm)

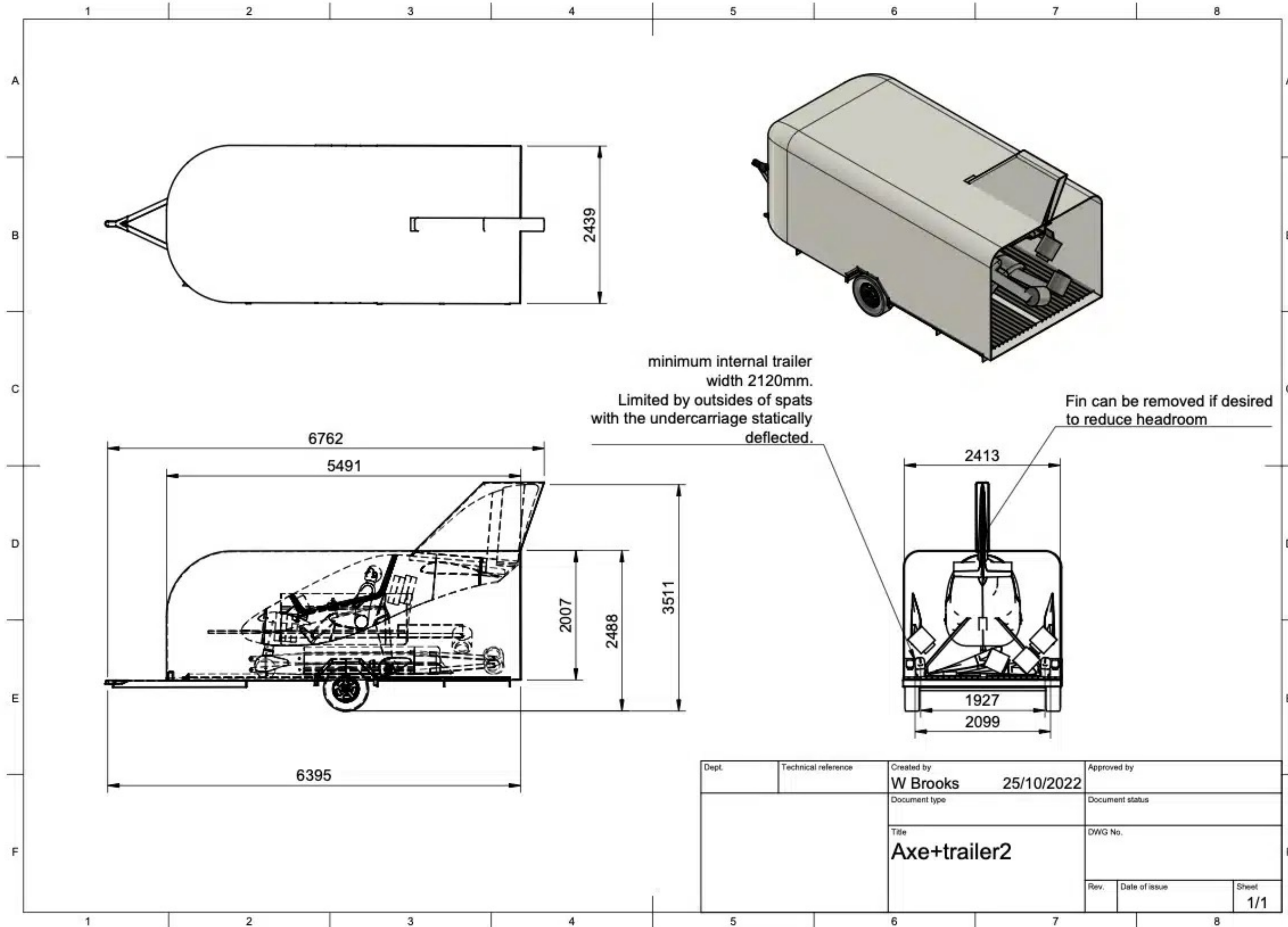

Flight Control System

The Veronte 4x is the chosen redundant flight control system for the Axe aircraft. The Veronte 4x features a fail-operational redundant architecture that has been designed for avoiding a single point of failure managed by a dissimilar arbiter board. The flight control system is certified to DO178C / ED-12 and DO254 aviation standards.

The flight control system can also be configured with a 4G module in the control system for integrating with online databases for air traffic and weather information. The flight controller is also compatible with a variety of collision avoidance sensors such ADS-B, radar or LIDAR.

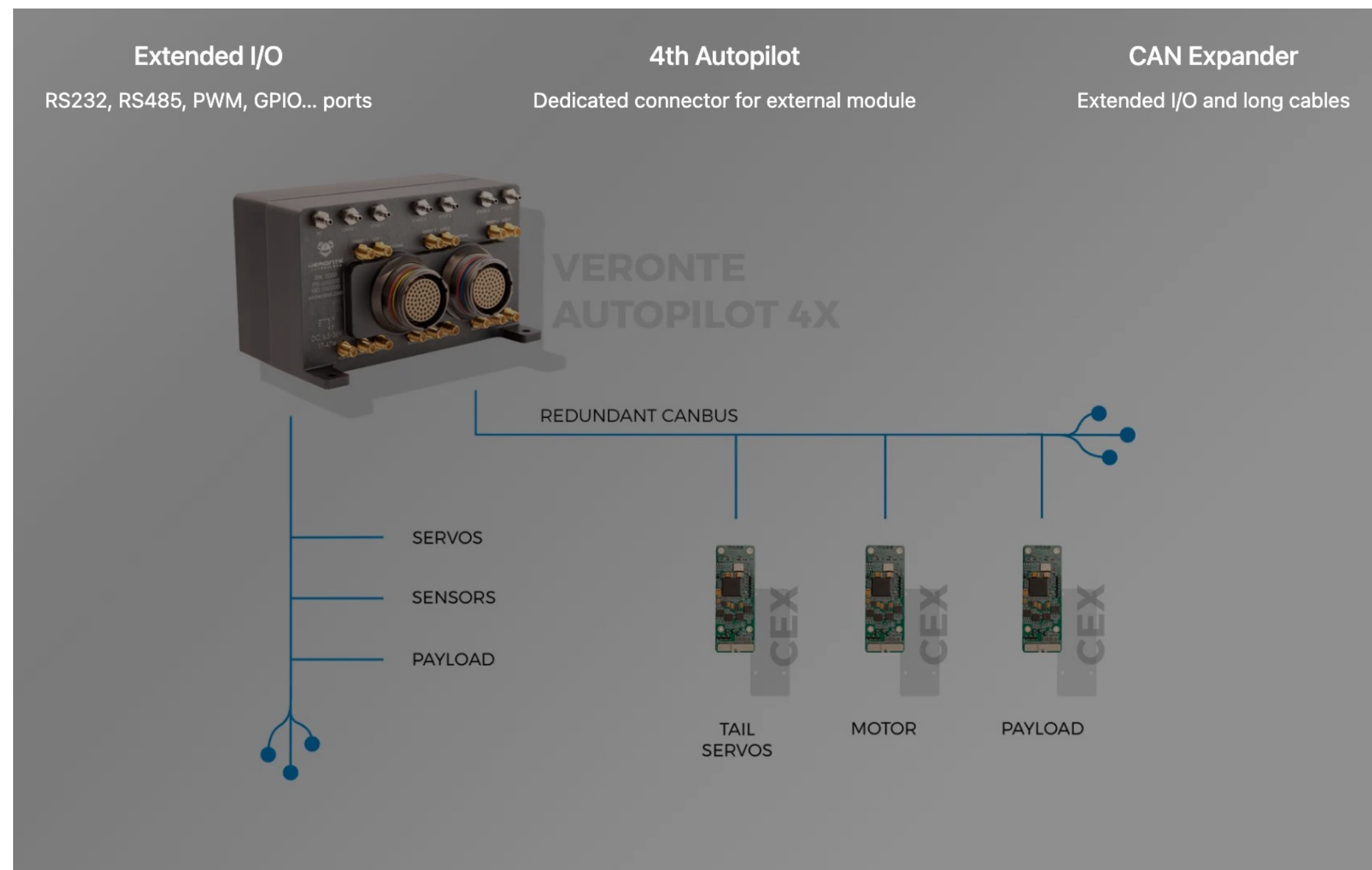

Safety & Reliability	
No SPOF	No single point of failure Robust to arbiter failure
3x Redundancy	Embedded triple redundancy
4x Redundancy	External autopilot core Main controller or fail-operational unit
Redundant power input	Up to 4 independent inputs
FTS (Flight Termination System)	Dissimilar microprocessors & regulation stages Automatic or manual activation
Internal redundancy	Redundant communication bus Kill me function on each core
Custom voting logics	Configurable voting logics and strategies
Reliability documents	DDP: Declaration of Design & Performance ATR: Acceptance Test Results COC: Certificate Of Compliance
Manufacturing process	Strict Acceptance Test Procedure (ATP) Conformal coat
ESS (Environment Stress Screening)	Temperature and vibration circles for early failure detection
DO160 & MIL-STD-810 Environmental test	Temperature, temperature variation, altitude, shock, vibration
DO178C Software reliability	DAL-B
DO254 Hardware reliability	DAL-B
Certification data pack	PSAC, SDP, CMP, SQAP, SVP, HVVP, HCMP, HPAP, TTR, SVGP, SQAR, SCI, SECI, SRD, TD, SVR, SCMR, SAS, PR, HRD, HDD, HTP, HVVR, HCMR.
Certification support	Dedicated engineering support
Software testing	24/7 testing environment Custom test for specific PDIs Iron bird setup
MTBF	4x10 ⁷ MTBF Project-based MTBCF calculation
Configurable failsafe	Custom events and actions Multiple safety levels
Warnings	Visual & sound alarms Customizable
User access level	Unlimited users Custom permissions

Sensor	
Redundancy	Redundant sensors on each autopilot core
9x Barometer	3x 0 to 103 kPa 3x 1 to 120kPa 3x 30 to 110 kPa
3x Pitot	3x 0.003kPa (5kt 8km/h sea level) to 6.9kPa (206kt 382km/h sea level) Up to 1570kt 2900km/h with optional external sensor
6x Accelerometers (3 axes)	6x ±16G 3x ±24G Sustained manoeuvre (peaks up to ±32g)
6x Gyroscopes (3 axes)	9x 125 to 2000 deg/sec (compensated)
6x Magnetometers (3 axes)	6x 16 gauss 3x 8 gauss
6x GPS	GPS, BeiDou, GLONASS RTK GNSS-based Attitude
4x Voltage	4x Input voltage sensor
3x Temperature	3x Internal temperature sensor
External sensors	Enhanced compatibility Navigation fusion

Propulsion components

HPD50 Duplex redundant electric motors

The motors in the Axe are from Geiger engineering and are electric aero-motors. Two mechanically and electrically separate individual motors work without gears on a propeller shaft, so that if there is a fault in one powertrain, the aircraft can continue its flight as normal.

Features:

- 42 suction drillings directly next to the motor windings allow for effective cooling through radial fans right the source of the heat
- Closed surface at the top of the motor ensures no foreign bodies enter the motor windings
- The usage of high-quality neodymium magnets, fully-processed electrical sheets of highest quality and allow airflow with smallest air gaps completes this high tech motor.
- Continuous communication between HMI <-> Battery <-> Power inverter which enables careful regulation by linked self-test routine and cascaded regulation and safety processes



SKYFLY

MC300 – Four-quadrant motor controller

Tailored to the motors, Geiger Engineering presents a new generation of motor controllers, which offer a range of functions specially for manned electric flight not available up to now on the market.

Features:

- High power density at low voltage level 60VDC (PELV) 300A – 600A continuous for 30 seconds
- Robust and modular construction
- Integrated functions specific for flight applications:
 - Adjustable airscrew control via airscrew characteristics
 - Airscrew positioning, electronic cams
 - Integrated release switching, Quick stop functions (parachute emergency stop, Virtual Coach etc.)
 - Reversing as use as airbrake or for maneuvering.
 - Cycle frequency management, and motor, battery and inverter temperature management to maintain availability if limit values are exceeded.
 - Integrated automatic self-test functions of battery, inverter and motor before each start

Master-Slave operation of two PI300 modules possible to extend power to 600A cont. / 1200A for 30s and to increase availability

Full four-quadrant operation (Recuperation, Traction)

Universal interfaces (Encoder, Hall sensors, RS485, RS232, analogue and digital activation)



axe

ROTRON

50 KW Hybrid Generator

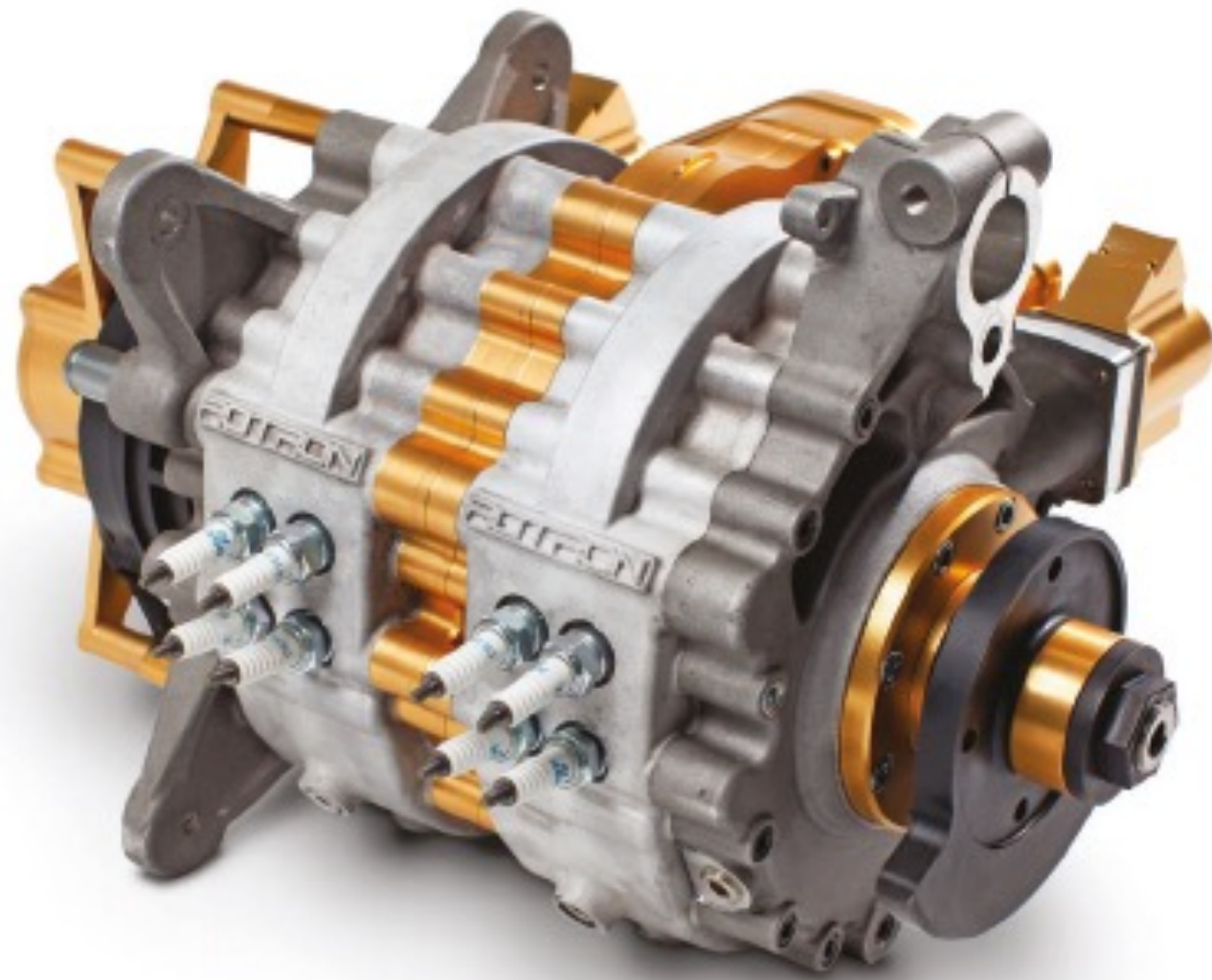

Increase endurance up to 3 hours
 50KW continuous power
 55kg all up weight

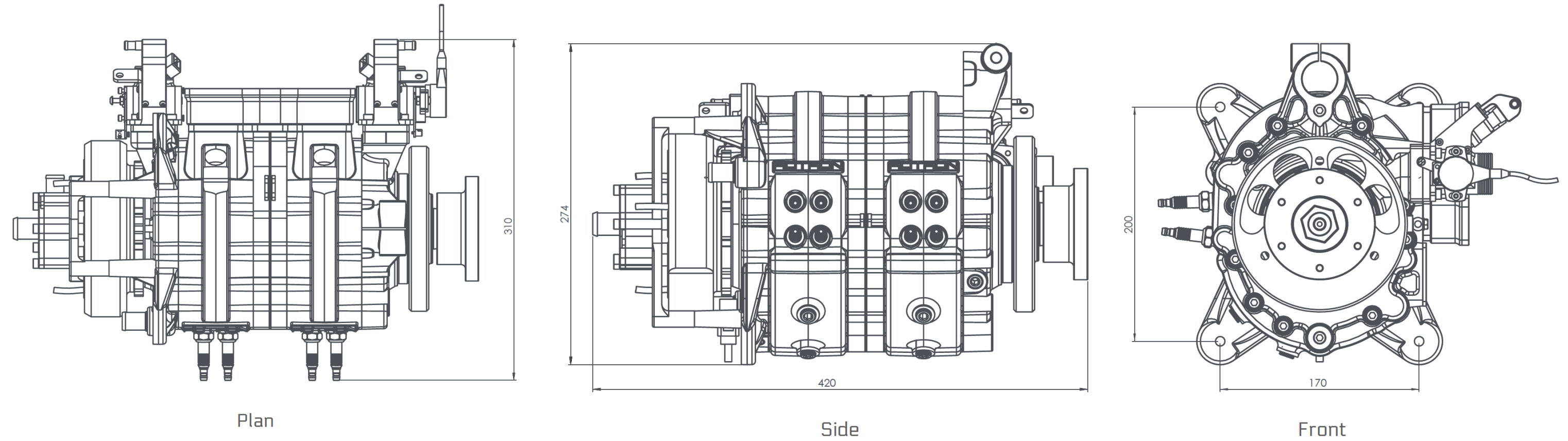

Working with Rotron we are adding the option for a hybrid generator system to extend the range of the aircraft. The Rotron rotary engine delivers an efficient and reliable solution for use with heavy fuels. This compact, twin rotor engine utilises advanced fuel management techniques to achieve reliability in operation, high power-to-weight ratio, low fuel consumption and reliable starting under the most extreme of operating conditions.

- For use with JP5, JP8 and Jet A1 heavy fuel
- High power-to-weight ratio with increased efficiency
- Compact package size allows greater fuel and payload flexibility for multi-mission capability
- Low levels of torsional and zero radial vibration at mid-to-high rpm range
- Fuel injection and ECU controlled altitude compensation fitted as standard
- Higher endurance lifecycle

Completed Engine TBO (Time between overhaul)

1000 hrs

Rotron continues to raise the benchmark for capability, endurance and reliability of their rotary engines by going beyond their original scoped service life.

Ballistic Parachute - Galaxy GRS

Model name	GRS 6 600 SD Speedy FF 115m	
Total safety coefficient of the canopy by ASTM F2316-12		Test ASTM 1,5
Allowed max. operational weight MTOW	Kg	600
Allowed never exceed speed for use VNE	Km/h	380
Maximum operational opening dynamic shock at VNE and MTOW	kN/G	30,0
Tested total time of full canopy in VNE and MTOW	sec.	6,0-6,5
Overall time of full canopy stretching at the speed of 95 km/hod. at MTOW	sec.	5,6-5,8
Descending recorded at 1000m/AMSL Min. Max MTOW m/s Descending recorded at 1500m/AMSL	m/s	7,1-7,3 7,3-7,5*
Maximum load at speed 250 km/h	Kg	750
Maximum operational opening dynamic shock at the speed 250 Km/h	kN	32,0
Minimum projected rescue height for horizontal fly	m./km/h	120/90 150/90*
Method ejection		Container Short sleeve

Canopy		
Area	m2	115
Number of lines and panels		26
Nominal diameter	m	10,6
Quantity of slots/Slider*		26/39*

Galaxy GRS was the first and now biggest European producer of parachute ballistic rescue systems aimed at ultralights, light sport and experimental aircraft ranging up to speed of 400 Km/h.

Ballistic device	Rocket engine MK4
Igniter – mechanical ignition	Dual primer
Stationary rocket engine pull	670 N/sec. 68Kg
Maximum rocket engine pull	930 N/sec. 94Kg
Ballistic and drawing device weight	2.62Kg
Burn time (- 40°C - +60°C)	1 sec. ± 0,2 sec.
Cycle Exchange	6 years

Dimensions		
Dimensions B1-B15 in products	mm	B1-B15
Weight unit - GRS	Kg	11,5
Drawing sling length weight	m. Kg	5,5 0,74
IN/OUT #/ Soft R + (0,75kg)	Kg	---
Total weight±4% GRS Soft B GRS Soft B2	Kg	12,3

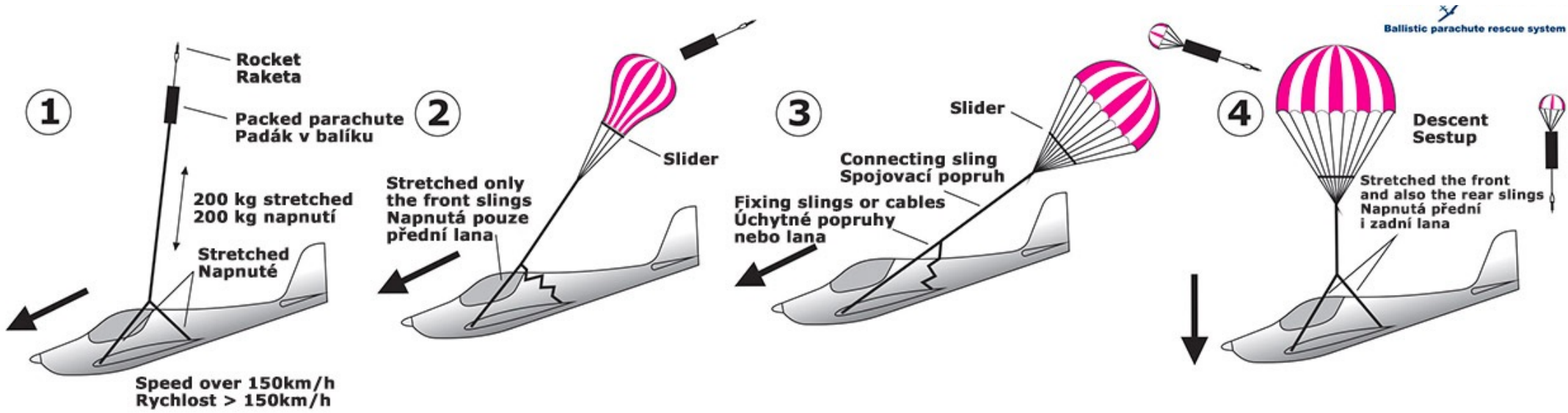



Mr. M. Thompson
Skyfly Technologies Ltd
London
SW6 3BU

1st June 2022

Dear Michael

I am pleased that the LAA is in a position to support the Skyfly project, with our engineering team working with you to develop means of engineering verification and compliance with the Civil Aviation Authority regulation, allowing this hugely exciting project to take to the skies.

We look forward to working with you, as Skyfly's technology is very much in line with the spirit of innovation which is a key part of our Association's DNA. Skyfly has the potential both to revolutionise sports and recreational aviation, and to also build for the future in terms of new, sustainable air transport concepts.

Here's to the next steps to get Skyfly` airborne!



Stephen Slater
CEO
Light Aircraft Association

Registered Office and Company Address:
Turweston Aerodrome, Nr Brackley, Northants, NN13 5YD
Tel: +44 (0)1280 846786 Fax: +44 (0)1280 846780
Email: office@laa.uk.com or engineering@laa.uk.com Web: www.laa.uk.com
Recognised by Sport England. Member of General Aviation Awareness Council, General Aviation Alliance,
The Royal Aero Club and EFLVA - European Federation of Light, Experimental & Vintage Aircraft.
The representative body in the UK for amateur aircraft construction, recreational and sport flying.
Light Aircraft Association Limited . Reg No. 606312 ENGLAND . VAT No. 665 1994 95



Existing Market – Personal aircraft



Type	Skyfly Axe 2 seat eVTOL	Robinson R22 2-Seater Piston Helicopter	Cessna 152 2-Seater Piston fixed wing
Pilot/Owner aspects	Unskilled pilot can fly with ease	Very Skilled pilot required - no easily integrated autopilot or autonomous capabilities and costly to run.	Skilled pilot required
Noise Profile	Low noise	Very High noise	High noise
Purchase Price	\$180,000	\$318,000	Approx \$200,000
Range	100 miles (300+ miles hybrid)	230 miles	477 miles
Est. Annual Cost per year	Approx. £6,200/\$7807 per annum (incl. charging, servicing and maintenance based on 100 hours per year)	Approx. \$34,000 (incl. fuel, servicing and maintenance based on 100 hours per year)	Approx. \$28,000 (incl. fuel, servicing and maintenance based on 100 hours per year)
Servicing required	Schedule to be advised by manufacturer and completed by owner	50-hour and 100-hr mandatory servicing required by expensive service centres	100 hr mandatory servicing
Aircraft life	7-year replacement on battery 300hr components replaced on life expiration date for Rotron petrol generator	2,200 hr life or 12 years of the aircraft life before major overhaul	1,800 hr TBO on engine
Depreciation	Depreciation based on age (like a car) – not on hours	Depreciation - Airframe depreciates to around £30,000 at the end of the 2200 hours	Approx. \$120,00 depreciation up to time of overhaul

Est. Annual cost per year calculation: Average PPL pilot will do maximum 100 hours a year. Batteries should be replaced every 1000 charge cycles (1000 hours) (approx £45000). Electricity cost approx. £12 per hour (£1200 per annum). Annual maintenance and inspection (maximum £500). 10 years battery life - £4500 per annum for battery replacement: **Total cost per year = £6200/\$7807 (£62/\$78 per hour) on 100 hours per year.**

Private Owners

For years, vertical flight has often been regarded as dangerous and high cost which has often led more pilots to opt for a fixed wing aircraft licence or no licence at all. The Axe by Skyfly offers a safe, easy to use and affordable solution to attract new pilots from both fixed wing aircraft and rotary aircraft backgrounds.

Cost

The cost of running electric aircraft is cheaper than piston or turbine aircraft. Electric motors have fewer moving parts, require less maintenance, and cheap(er) electricity means costs may fall by more than half of existing piston and turbine alternatives. Through the Permit to Fly route of certification, costs are dramatically reduced as you are not tied into expensive, 25, 50 and 100 hour mandatory servicing schedules at designated service centres that often burden private owners. Also, you can carry out your own maintenance.

Usability

Traditional vertical flight (helicopters) requires a high level of skill from the pilot with some pilots not being able to get past the hover in training. This is often why pilots opt for a fixed wing license rather than getting their helicopters pilots license. The flight controllers in the Axe aircraft provide the pilot with a lower work load and minimal flight control inputs, with the flight controller doing the majority of the heavy lifting - especially in high winds. If you can fly a small consumer drone, you can fly the Axe aircraft.

Safety

Multiple motors enables you to have redundancy in critical flight phases. If one motor fails, you can still fly safely. Compared to a single engine helicopter where there is only a single source of power, distributed propulsion is a proven safety feature. Furthermore, brushless electric motors compared to conventional piston or turbine engines have far fewer moving parts and critical components that can fail. Finally, with the Axe you can glide like a fixed wing in emergencies and have the back-up of a ballistic parachute.

European Private Pilot Market

Est. £46 Billion

UK Private Pilots

There are approx. 35,000 UK Registered Pilots and around 20,000 UK Registered GA Aircraft.

There is also an influx of around 3500 new pilots each year that are looking to purchase aircraft.

This offers an estimated £6.9 Billion Market Value

European Private Pilots

Based on information provided by the NAA, 103,063 GA aircraft are registered and 185,123 pilot licences were delivered for 2014 in Europe.

Whilst there is little published data across Europe, based on growth trends, this figure can be assumed to be over 200,000 pilots.

This offers an estimated £40 Billion Market Value

“The Ultralight and Light Aircraft Market is projected to grow from an estimated USD 5.5 billion in 2020 to USD 11.6 billion by 2030, at a CAGR (compound annual growth rate) of 7.7% during the forecast period. This is due to the increasing number of high net worth individuals, upcoming new aircraft programs, and ageing aircraft. Though the market has witnessed a slow growth in recent years, aircraft with Vertical Take-off and Landing (VTOL) capability and environment-friendly propulsion technologies, including electric and hybrid engines, are expected to reduce the operating costs drastically and serve as an opportunity for the market growth up to 2030.”

Sources – Civil Aviation Authority, NAA, Markets and Markets

Training Organisations

When eVTOLs become certified for autonomous operation in the coming decade or so, pilots will remain necessary for their operation. This means the industry will need to train large numbers of pilots for eVTOL flights. (80,000 pilots approximately by 2028). The Axe's fixed-wing forward flight and conventional take-off capability makes it the ideal trainer for pilots to transition from fixed-wing aircraft to eVTOLs. Also, the design can train new pilots the skills and control necessary to land an aircraft without power (an essential tool). The Axe's electronic flight control system and its easy VTOL transitions will smoothly introduce any new flier to eVTOL flight, whether experienced or otherwise. And this trainer won't break the bank. Its low weight, low purchase price, and low operating costs are yet another reason why the £2bn training market is about to receive the perfect eVTOL pilot trainer.

Cost

The cost of running electric aircraft is cheaper than piston or turbine aircraft. Electric motors have fewer moving parts, require less maintenance, and cheap(er) electricity means costs may fall by more than half of existing piston and turbine alternatives. The Permit to Fly regime offers more flexibility on costs and means that the Axe can be maintained and inspected, and have their Permits to Fly renewed annually, by the Light Aircraft Association. Flight training organisations are not tied into expensive service centres.

Usability

The aircraft is fitted with a removable battery module which enables you to continue flying, even when the main battery has run out. This enables you to have shorter charge times on your main battery pack and quicker turnaround times on the ground. If equipped with a hybrid generator, your training aircraft is capable of competing with existing piston training alternatives. With removable wings, the Axe can be transported on a trailer giving Flight training organisations ultimate flexibility on where they train students.

Safety

Multiple motors enables you to have redundancy in critical flight phases. If one motor fails - you can still fly safely. Compared to a single engine helicopter where there is only a single source of power, distributed propulsion is a proven safety feature. Furthermore, brushless electric motors compared to conventional piston or turbine engines have far fewer moving parts and critical components that can fail. Finally, with the Axe you can glide like a fixed wing in emergencies and have the back-up of a ballistic parachute.

Global training market for eVTOL pilots

Est. £2.25 Billion up to 2028 and rising

The global aviation industry has struggled to recruit and train enough experienced pilots to fill the cockpits of airlines, business aviation and helicopter operators. There is a growing industry realisation that the development of eVTOL aircraft and launch of AAM operations will further increase demand for professional pilots commencing by 2023-2025. (CAE 2021 Report)

It is forecast that there will be a requirement for around 60,000 pilots for the UAM sector by 2028. (See McKinsey & Company report on rising pilot requirements)

With our route to certification and operating costs, running costs will remain low, giving flight schools a cost effective aircraft to train pilots in this new sector of aviation.

Urban air mobility (UAM) will accelerate demand for pilots.

Number of pilots required to fulfill urban-air-mobility (UAM) need in next decade

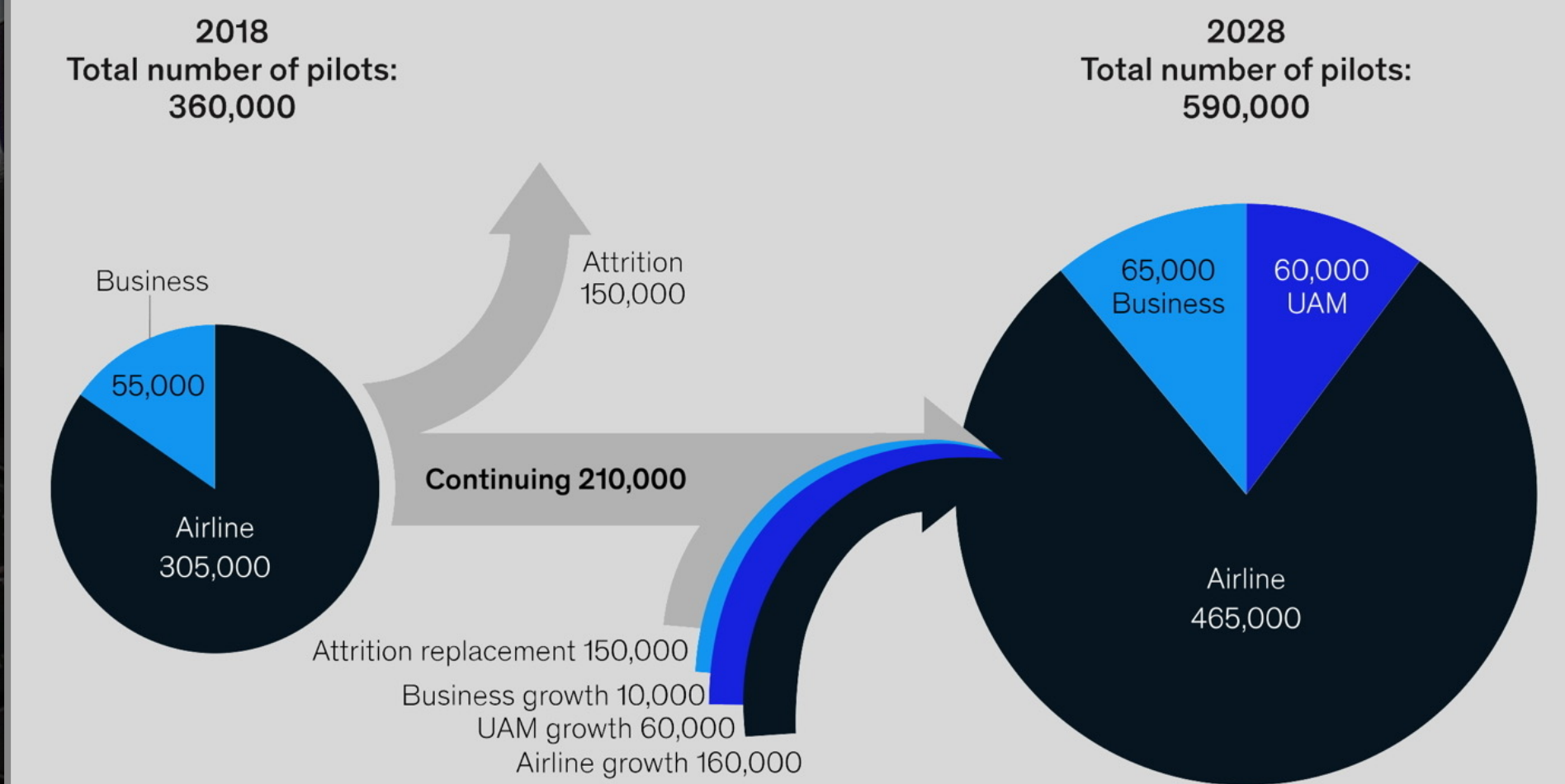

Note: Numbers are rounded.

Source: McKinsey Flight Crew Model, CAE Airline and Business Jet Pilot Demand Outlook, 10-year view, 2018 Update

McKinsey & Company

Order now for delivery 2025. Visit www.skyflytech.com/order.

Investor Contacts:

jaap.rademaker@skyflytech.com

michael.thompson@skyflytech.com

